



KuDymond

CS3K-275 | 280 | 285P-FG

MORE POWER



Low power loss in cell connection



Low NMOT: $42 \pm 3 \text{ }^\circ\text{C}$
Low temperature coefficient (Pmax): $-0.38 \text{ \% / }^\circ\text{C}$



Better shading tolerance

MORE RELIABLE



Lower hot spot temperature



Minimizes micro-cracks



Heavy snow load up to 5400 Pa,
wind load up to 2400 Pa



Fire Class A and Type 3 / Type 13 certified
according to IEC 61730-2 / MST 23 and UL 1703

*Transparent doubleglass module can be provided upon request.



linear power output warranty



product warranty on materials and workmanship

MANAGEMENT SYSTEM CERTIFICATES

ISO 9001:2015 / Quality management system
ISO 14001:2015 / Standards for environmental management system
OHSAS 18001:2007 / International standards for occupational health & safety

PRODUCT CERTIFICATES*

IEC 61215 / IEC 61730: VDE / CE
UL 1703: CSA / IEC61701 ED2: VDE / IEC62716: VDE
Take-e-way



*We can provide this product with special BOM specifically certified with salt mist, ammonia and sand blowing tests. Please talk to our local technical sales representatives to get your customized solutions.

CANADIAN SOLAR INC. is committed to providing high quality solar products, solar system solutions and services to customers around the world. No. 1 module supplier for quality and performance/price ratio in IHS Module Customer Insight Survey. As a leading PV project developer and manufacturer of solar modules with over 30 GW deployed around the world since 2001.

CANADIAN SOLAR INC.

545 Speedvale Avenue West, Guelph, Ontario N1K 1E6, Canada, www.canadiansolar.com, support@canadiansolar.com

ENGINEERING DRAWING (mm)

Rear View

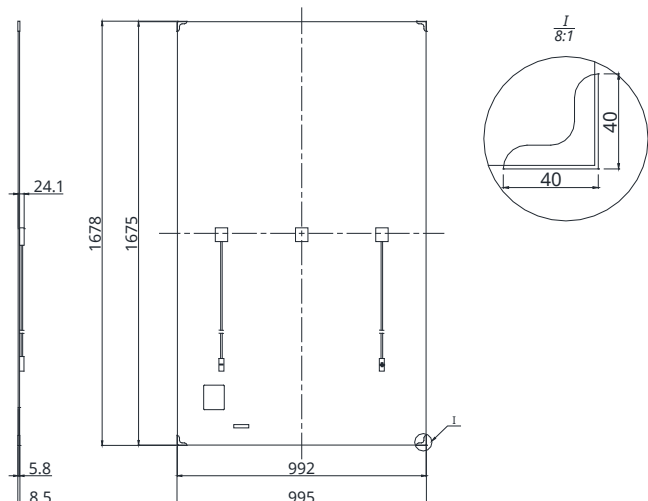

ELECTRICAL DATA | STC*

CS3K	275P-FG	280P-FG	285P-FG
Nominal Max. Power (Pmax)	275 W	280 W	285 W
Opt. Operating Voltage (Vmp)	31.0 V	31.2 V	31.4 V
Opt. Operating Current (Imp)	8.88 A	8.98 A	9.08 A
Open Circuit Voltage (Voc)	37.7 V	37.9 V	38.1 V
Short Circuit Current (Isc)	9.38 A	9.47 A	9.56 A
Module Efficiency	16.55%	16.85%	17.15%
Operating Temperature	-40°C ~ +85°C		
Max. System Voltage	1500V (IEC) or 1000V (IEC/UL)		
Module Fire Performance	TYPE 3 / Type 13 (UL 1703) or CLASS A (IEC61730)		
Max. Series Fuse Rating	30 A		
Application Classification	Class A		
Power Tolerance	0 ~ + 5 W		

* Under Standard Test Conditions (STC) of irradiance of 1000 W/m², spectrum AM 1.5 and cell temperature of 25°C.

ELECTRICAL DATA | NMOT*

CS3K	275P-FG	280P-FG	285P-FG
Nominal Max. Power (Pmax)	204 W	208 W	211 W
Opt. Operating Voltage (Vmp)	28.6 V	28.8 V	29.0 V
Opt. Operating Current (Imp)	7.12 A	7.21 A	7.29 A
Open Circuit Voltage (Voc)	35.2 V	35.4 V	35.6 V
Short Circuit Current (Isc)	7.57 A	7.64 A	7.71 A

* Under Nominal Module Operating Temperature (NMOT), irradiance of 800 W/m², spectrum AM 1.5, ambient temperature 20°C, wind speed 1 m/s.

* The specifications and key features contained in this datasheet may deviate slightly from our actual products due to the on-going innovation and product enhancement. Canadian Solar Inc. reserves the right to make necessary adjustments to the information described herein at any time without further notice. Please be kindly advised that PV modules should be handled and installed by qualified people who have professional skills and please carefully read the safety and installation instructions before using our PV modules.

CANADIAN SOLAR INC.

545 Speedvale Avenue West, Guelph, Ontario N1K 1E6, Canada, www.canadiansolar.com, support@canadiansolar.com

CS3K-280P-FG / I-V CURVES

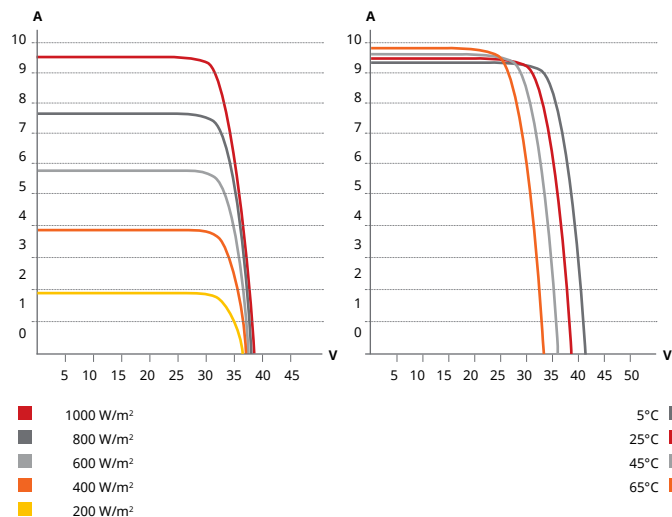

MECHANICAL DATA

Specification	Data
Cell Type	Poly-crystalline
Cell Arrangement	120 [2 x (10 x 6)]
Dimensions	1675 X 992 X 5.8 mm (65.9 X 39.1 X 0.23 in) without J-Box and corner protector
(Incl. corner protector)	1678 X 995 X 8.5 mm (66.1 X 39.2 X 0.33 in) without J-Box
Weight	24 kg (52.9 lbs)
Front / Back Glass	2.5 mm heat strengthened glass
Frame	Frameless
J-Box	IP68, 3 bypass diodes
Cable	4.0 mm ² (IEC), 12 AWG (UL),
Cable Length (Including Connector)	Portrait: 400 mm (15.7 in) (+) / 280 mm (11.0 in) (-); landscape: 1160 mm (45.7 in)*
Connector	T4 series
Per Pallet	33 pieces
Per Container (40' HQ)	858 pieces

* For detailed information, please contact your local Canadian Solar sales and technical representatives.

TEMPERATURE CHARACTERISTICS

Specification	Data
Temperature Coefficient (Pmax)	-0.38 % / °C
Temperature Coefficient (Voc)	-0.31 % / °C
Temperature Coefficient (Isc)	0.05 % / °C
Nominal Module Operating Temperature	42 ± 3°C

PARTNER SECTION

